



We get the joy.™

SMART SCOOP®

SMARTSTART GUIDE FOR A FRESHER LITTER BOX

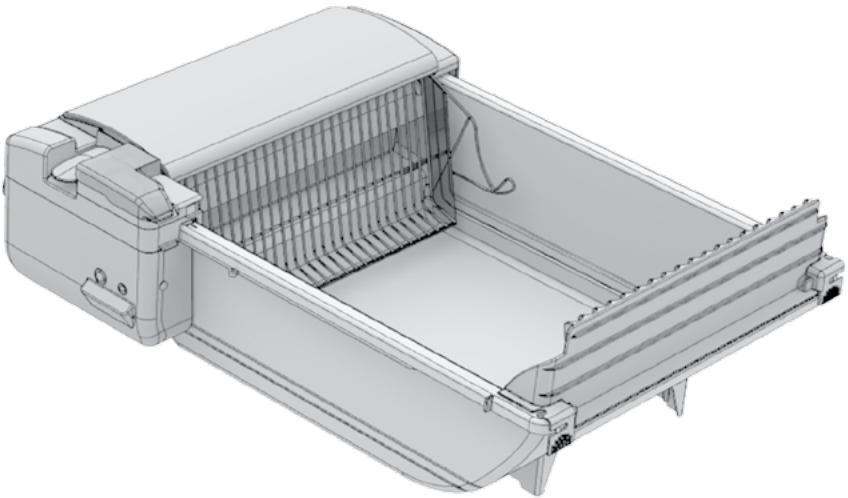

TABLE OF CONTENTS

Introduction to Smart Scoop®	4
How It Works.....	4
Safety Features and Precautions	5
Unpacking Components	6
Smart Scoop Parts List.....	7
Setting Up Smart Scoop	7
Indicator Light	10
Using No-Touch Waste Bags & Activated Carbon Filters ...	10
Using Smart Scoop.....	11
Introducing Your Cat to Smart Scoop	11
A Word About Litter	12
Care and Cleaning.....	13
Warranty	14
FAQ.....	15
Troubleshooting	17
Customer Care	18
Other Great Smart Scoop Products	19

SmartScoop is a registered trademark of PetZone®.

INTRODUCTION TO SMART SCOOP

Thank you for purchasing the Smart Scoop Automatic Litter Box!

Smart Scoop was created to meet the challenge of litter box odor and mess. We knew there was a need for a more effective automatic litter box, so we designed an innovative solution to make your life easier. Now you can spend more time with your cat and less time with the box!

This guide will help you set up the Smart Scoop Automatic Litter Box, help your cat adjust to using the box, and provide care and cleaning tips to keep it working smoothly and efficiently.

If at any time you need detailed information on setup, such as pictures, instructions and videos, please visit www.petzonebrand.com. You can also give us feedback or suggestions by emailing customerservice@ourpets.com.

Enjoy your Fresher Litter Box!



Dr. Steve Tsengas
President and CEO
Pet Zone

HOW IT WORKS

The Smart Scoop Automatic Litter Box features a sensor that detects when your cat is in the box. Once the cat leaves the box, it begins a 15-minute countdown. After the countdown, Smart Scoop begins a cleaning cycle and scoops the box clean of waste and clumps. Clumps and waste are deposited in the waste bin and the motor unit returns to the “ready” position at the back of the box.

SAFETY FEATURES AND PRECAUTIONS

Do not use Smart Scoop until you have read and understand these instructions, or damage may result.

NOTE: The safety features listed below are not all-inclusive. They are meant to inform you of the major safety features and to warn you of typical safety issues. IT IS NOT AN ABSOLUTE GUARANTEE OF SAFETY.

- The Smart Scoop Automatic Litter Box features a sensor that detects when your cat is in the box. Once your cat leaves the box, a 15-minute countdown begins.
- The motor unit will stop if it encounters excessive resistance.
- Avoid contact with moving parts. Do not insert your hand into the box if the motor unit is moving.
- For added safety, Smart Scoop comes with a breakaway power cord that separates if someone trips over the cord. Keep the cord away from areas where it could become a trip hazard. Do not operate the product if the cord becomes frayed or damaged.
- Do not let small children play around the litter box. Closely supervise any child that is assisting you in the care and operation of this product.
- Pregnant women, small children and those with reduced immune systems should avoid coming into contact with cat waste to reduce the risk of exposure to potentially dangerous organisms.
- Always remember to wash your hands after handling used cat litter.
- NEVER clean Smart Scoop with water, or disassemble unit, while it is plugged in. Always unplug before cleaning. Use care in cleaning Smart Scoop; some cleaning products may be harmful to your cat.
- This product is meant for indoor use only. Do not use in a wet environment or harsh environment such as a garage, patio or attic.
- Not intended for kittens under 6 months of age.
- Use of accessories or attachments that are not recommended by the manufacturer have not been tested for safety and could hinder the operation of the product.

This product is intended for the safe elimination of cat waste. DO NOT USE THIS PRODUCT FOR ANY OTHER PURPOSE.

WARNING: The power cord on this product contains lead, a chemical known to the State of California to cause cancer, and birth defects or other reproductive harm. Wash hands after handling.

UNPACKING COMPONENTS

The Smart Scoop Automatic Litter Box is packaged to provide protection during shipping. Please remove all components from packing material very carefully.

Please familiarize yourself with the contents of the package. If any components are missing or damaged, please contact our customer care professionals.

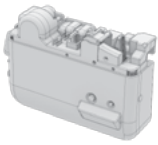

(1) Motor Unit

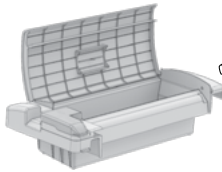

(1) Waste Unit

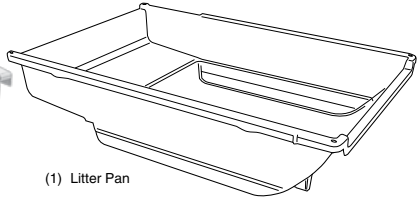

(1) Litter Pan

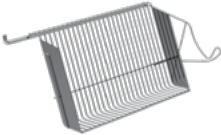

(1) Litter Rake

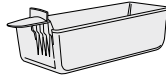

(1) Waste Tray



(1) Power Supply



(1) Activated Carbon Filter

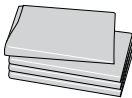

(4) No-Touch Waste Bags



(1) Litter Rake Comb



(1) Waste Deflector

Packing bags are not toys! Please dispose of properly and keep them away from children and pets!

SMART SCOOP PARTS LIST

Individual parts are orderable after warranty period expires.

Description	Part No.
Motor Unit	11342027
Waste Unit	11342028
Latch Cover	11342029
Waste Unit Lid	11342030
Litter Pan	11342031
Litter Rake	11342032
Waste Tray	11342033
Power Supply	11342034
Litter Rake Comb	11342035
Waste Deflector	11342036

SETTING UP SMART SCOOP

Detailed instructions, including pictures and videos, are available online at www.petzonebrand.com.

- 1 Locate motor unit - turn clutch handle clockwise to the “unlocked” position.

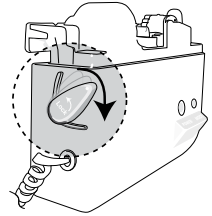

- 2 Align motor unit with litter pan edge as shown, slide forward until leading edge is aligned with line on litter pan (an arrow points to the line (A)).

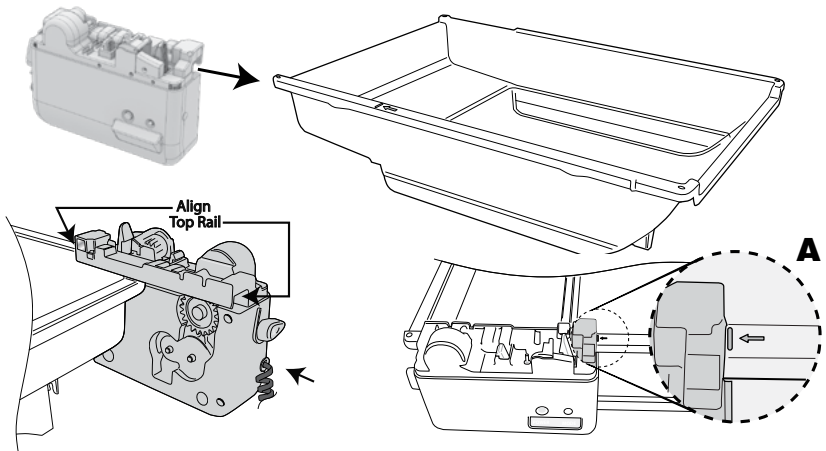

- 3** Engage clutch by turning the lever counterclockwise to the “locked” position

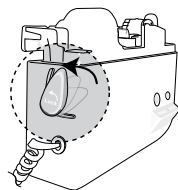

- 4** Lift the plastic latch cover, and align waste unit vertically above motor unit, push down lightly until waste unit aligns and latches engage (you will hear a “CLICK”).

- ❗ Make sure the waste unit and motor unit are fully engaged and there is no gap between them (A).
- ❗ Make sure that latch is engaged (B).

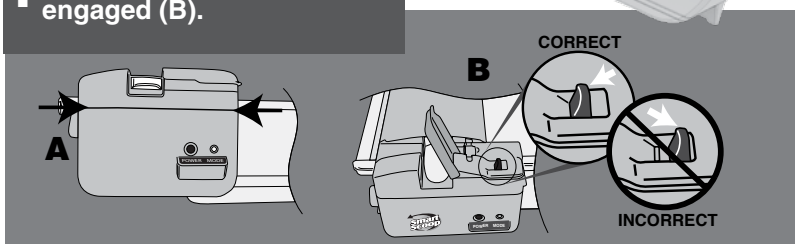
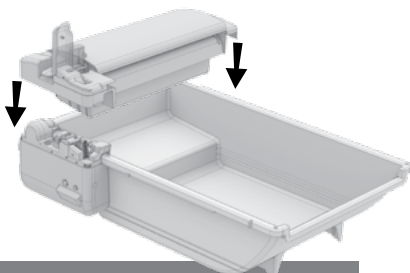

- 5** Next, place the straight end of the litter rake into the hole in the waste unit (A). Then insert the curved end into the rake slot with the end pointing upward (B). **Note: you will need to hold the rake safety door open to assemble the litter rake properly. When you release the rake safety door, it will spring closed.**

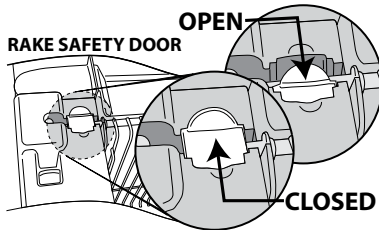
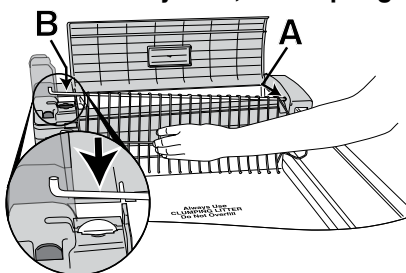

- 6** Close the latch cover (A). The rake safety door should always be closed (B).

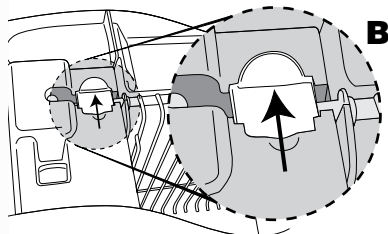
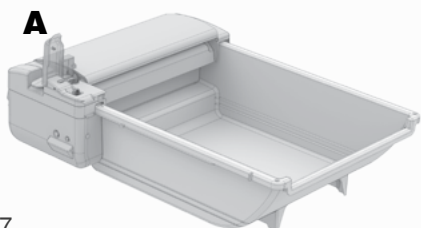

- 7** To install the waste deflector, snap it into the groove located at the end of the litter box.



- 8** Locate AC power supply. Connect breakaway power supply cord to cord originating from motor unit.

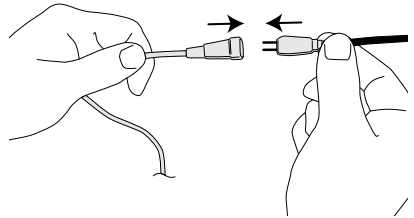

- 9** Fix power supply cord collar from motor unit into the slot located on the underside of the litter pan.

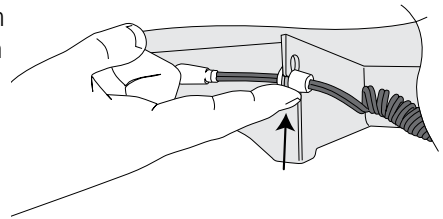

- 10** Fill with clumping litter. Do not exceed the “Maximum” line indicated inside litter pan. Overfilling will damage the motor unit.

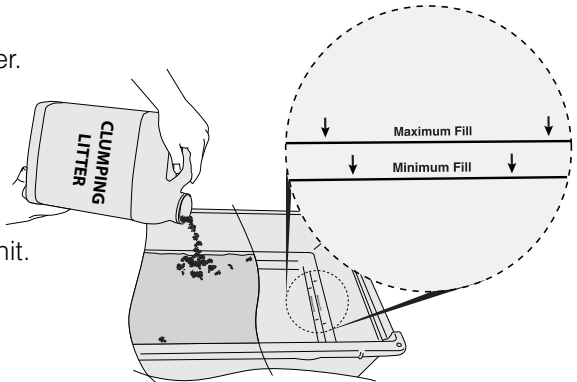

- 11** Plug AC power supply into outlet.

- 12** Press POWER button on motor unit to power-on Smart Scoop (Clutch lever must be rotated into “locked” position to turn on power). When Smart Scoop is on, the MODE light will be solid green. Your litter box is now ready to go and will automatically complete a cleaning cycle 15 minutes after your cat leaves the box.

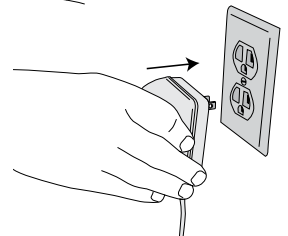

MODE INDICATOR LIGHT

The MODE indicator light shows the status of Smart Scoop Automatic Litter Box:

Green, solid: Unit is powered on and monitoring for cat activity.

Green, blinking: Unit has detected a cat and is waiting 15 minutes to begin cleaning cycle.

Red, solid: Unit has encountered excessive resistance. Turn off the unit, unlock the clutch, remove obstruction, slide waste unit back into “ready” position, lock clutch and turn it back on.

Red, blinking: Last cleaning cycle failed to complete. Unit has detected a cat and is waiting 15 minutes to begin cleaning cycle.

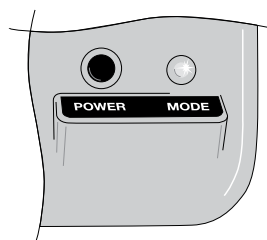

USING NO-TOUCH WASTE BAGS AND ACTIVATED CARBON FILTERS

To install Smart Scoop No-Touch Waste Bags, simply slide bag over waste tray and push it down so bag hugs walls and creates a place for waste to accumulate. Tuck bag excess under waste tray handle. Lightly push tray into waste unit so it fits snugly.

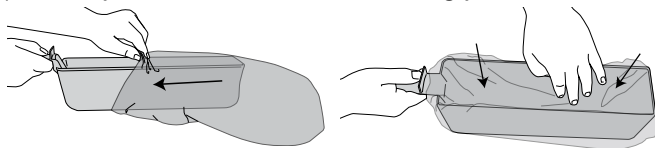

To remove No-Touch Waste Bags when they are full, simply peel back the bag over the waste tray and tie it closed. Disposing of litter is easy, clean and you never have to come in contact with clumps and waste.

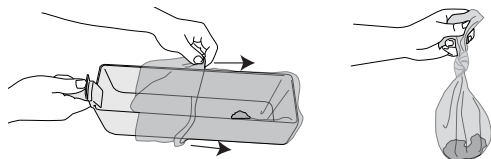

To install Activated Carbon Filter, simply place filter in square located on waste tray lid and press filter onto pin. We recommend replacing the activated carbon filter every time you replace the waste bag to keep odors to a minimum.

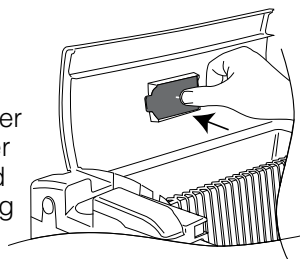

USING SMART SCOOP

Before powering on Smart Scoop, make sure the following are in order:

- Clutch is in the “locked” position
- Waste unit is securely fastened to the motor unit (you’ll hear a “CLICK”)
- Rake is properly installed and rake safety door is closed
- Power cord is properly fastened to underside of pan and the unit is plugged in

Do not manually force motor unit while moving or stationary; this may damage gears or motor.

To begin operation, press the POWER button. SmartScoop is in automatic mode. The MODE light will be solid green, indicating power is on. SmartScoop will be at rest until a cat is detected. Upon detecting a cat leaving, SmartScoop will begin a 15-minute countdown before beginning a cleaning cycle. This countdown will be indicated by the MODE LED blinking green.

If the MODE LED is red, something may be disturbing the path of travel. If this is the case, turn off the unit, unlock the clutch, remove obstruction, slide waste unit back into “ready” position, lock clutch and turn it back on.

INTRODUCING YOUR CAT TO SMART SCOOP

Your cat may need your help and patience to become accustomed to the Smart Scoop Automatic Litter Box. Here are some tips:

Place Smart Scoop in the same location as your cat’s existing litter box. Give your cat some time to explore the new box, but keep the old litter box nearby so there is a familiar back-up. It may help to add a scoop or two of litter from the old box so there is a familiar scent in Smart Scoop.

Smart Scoop is relatively quiet when operating, but it will help to leave the unit unplugged for a few days so your cat begins using it just like an ordinary litter box.

Once your cat has become comfortable with Smart Scoop, do not clean the old litter box because cats will choose a clean box over a dirty one. We know changing litters can be traumatic for your cat, so we made sure that the Smart Scoop Automatic Litter Box could use any clumping litter. Using your regular litter will also help your cat quickly adjust to using a new litter box. Fill the box with clumping litter, and it's ready to go!

A WORD ABOUT LITTER

Only clumping cat litter should be used with Smart Scoop. We DO NOT recommend using non-clumping clay litter, pine or newspaper based litter. Smart Scoop relies on a litter's clumping properties to help pick up and dispose of waste, and these types of litter do not clump.

If you are currently using a pine or paper litter, you can easily transition to using a clumping litter. For the first few days, use the old litter in the Smart Scoop box without plugging in the unit. Next, create a layer in the bottom of the pan with the old litter and create a layer of clumping litter on top. Every few days add more clumping litter and remove more of the old litter until the box is entirely clumping litter. This will make the litter transition less stressful for your cat.

Caution - *DO NOT overfill with litter!* Do not exceed the "Maximum" line indicated inside litter pan. Overfilling will make it much harder for the unit to operate and will cause premature failure of the motor unit.

CARE AND CLEANING

We do not recommend turning off the Smart Scoop Automatic Litter Box at night. In order to operate efficiently, the unit must be able to clean the box after a cat has used it. If the unit is off all night, extremely large clumps can develop which could keep the unit from operating properly. Cats are most active at night so Smart Scoop needs to remain powered on to take care of their nighttime trips to the litter box.

Let's be honest. Automatic litter boxes alleviate the daily chore of scooping the box, but every litter box needs routine maintenance. Smart Scoop has been designed with ease of cleaning in mind. Its simple design allows the unit to be disassembled into easily-cleanable sections. **All of the sensitive electronics contained in the motor unit must never get wet.** All other parts of the litter box can be submerged in warm, soapy water for cleaning.

To disassemble for routine cleaning and maintenance:

- Unplug unit from power source.
- Disconnect power cord.

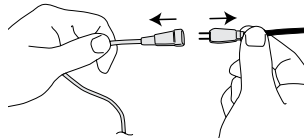

- To clean metal rake, open plastic latch cover (1), open rake safety door (2) and pull rake up and away from waste unit (3).

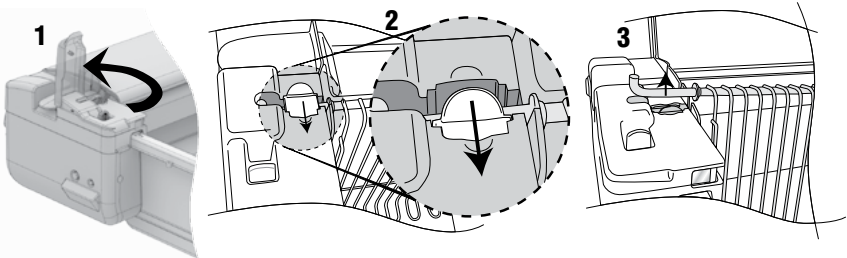

- To remove waste unit, flip up latch cover (1), depress latch (2) and lift waste unit straight up and away from motor unit (3).

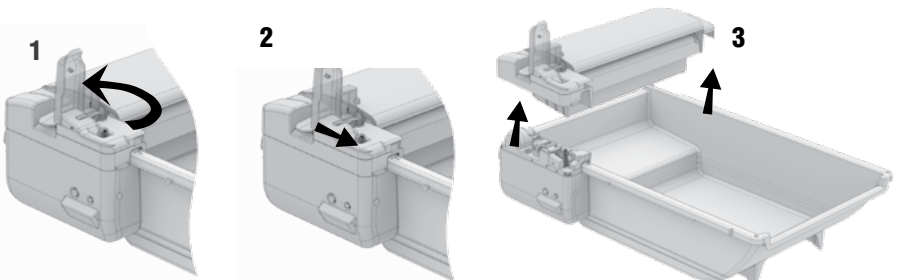

- Disengage clutch (A) by turning lever to the right and slide motor unit (B) off of litter pan.

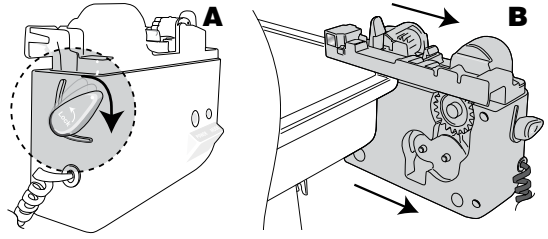

- To remove deflector for cleaning, simply pull tabs and pull deflector upward, away from litter box.
- Waste unit, waste tray, litter rake, waste deflector and litter pan can be washed with mild soap and water. Rinse and dry components before reassembling unit.

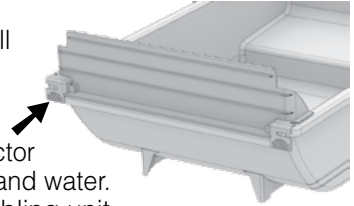

- **DO NOT SUBMERGE MOTOR UNIT IN WATER OR GET MOTOR WET.**

If motor unit needs to be cleaned, wipe with a damp cloth and dry immediately. Do not wash any components in a dishwasher.

It is important to keep the sensor lens clean and free of dust. After adding or changing litter, wipe the sensor cover with a soft, dry cloth to keep the sensor operating properly.

We have included a Smart Scoop litter rake comb that can be used to remove any small litter clumps that may adhere to the rake. Simply scrape the tines of the rake with the comb.

WARRANTY

Important: KEEP YOUR RECEIPT OF PURCHASE! You will need to provide proof of purchase for any and all warranty claims.

Pet Zone warrants that this Automatic Litter Box is free from defects due to faulty materials or workmanship. The warranty period is for one (1) year and commences on the Date of Purchase which is the date on your sales receipt. If your Smart Scoop Automatic Litter Box does not function as warranted during the warranty period, OurPet's Company will, at its sole option, repair or replace any components which fail in normal use. Such repairs or replacement will be made at no charge to the customer for part(s), provided that the customer shall be responsible for any transportation cost(s). This warranty does not cover failures due to abuse, misuse, accident or unauthorized alterations or repairs.

THE WARRANTIES AND REMEDIES CONTAINED HEREIN ARE EXCLUSIVE AND IN LIEU OF ALL OTHER WARRANTIES, WHETHER EXPRESS, IMPLIED OR STATUTORY, INCLUDING ANY LIABILITY ARISING UNDER ANY WARRANTY OF MERCHANTABILITY OR FITNESS FOR A PARTICULAR PURPOSE, STATUTORY OR OTHERWISE. THIS WARRANTY GIVES YOU SPECIFIC LEGAL RIGHTS, WHICH MAY VARY FROM STATE TO STATE.

For instructions regarding repair or replacement, please email **customerservice@ourpets.com** or call **1-800-565-2695**.

Smart Scoop is committed to your satisfaction, and we want you to be happy with your purchase. We will do our best to resolve any assembly, operation or performance issues with Smart Scoop, but we cannot accept returns or refund purchases made at retail stores. All returns and refunds must go through the store, website or catalog from which you purchased Smart Scoop and are subject to their return and refund policy.

Be sure to register your product online at **www.petzonebrand.com**.

FAQ (FREQUENTLY ASKED QUESTIONS)

What kind of litter can I use?

Smart Scoop was designed to use clumping litters so you do not have to switch cat litter (which can be very traumatic to a cat). We DO NOT recommend using non-clumping clay litter, pine or newspaper based litter. Using a clumping litter ensures that liquid waste will form solid clumps that the unit can remove from the box.

Can my kitten use Smart Scoop?

We do not recommend Smart Scoop for kittens under 6 months old or when kittens under 6 months old are in the house.

How much litter do I use?

Fill the Smart Scoop with litter being careful not to exceed the "Maximum" line on the inside of the litter pan. DO NOT OVERFILL with litter. Overfilling will cause damage to the motor unit.

How often do I need to empty and refill my litter?

In a one-cat household, the litter should be emptied and the box cleaned and re-filled with fresh litter about once a month. If there is more than one cat in your household, it may need to be changed more frequently.

Will I ever need to add litter?

Since litter is removed daily, you may need to add a small amount of litter every few days.

How often do I need to change the No-Touch Waste Bags?

All cats are different, but in a one-cat household, the No-Touch Waste Bags should be replaced about once a week. If there is more than one cat in your household, they may need to be changed more frequently.

How often do I need to change the Activated Carbon Filters?

We recommend changing the filter every time you replace the waste bag, or weekly at minimum for maximum odor control.

I have more than one cat. Can I still use Smart Scoop?

Absolutely! Smart Scoop features more usable litter area than most other automatic litter boxes which makes it ideal for multiple cat households.

Are the electronics safe for use around my cat?

Yes. All electronics are safely enclosed in the motor unit where cats cannot reach them.

How often do I need to clean Smart Scoop?

Automatic litter boxes alleviate the daily chore of scooping the box, but every automatic litter box still needs routine maintenance. That's something that other litter box makers don't want to tell you, but this is where the Smart Scoop really shines. Its simple design allows the unit to be disassembled into easily-cleanable sections.

Every few days, you may need to remove small clumps that are too small for the litter rake to pick up. We recommend a once-a-month cleaning for the entire litter pan and waste unit, and replacement of litter, for a one-cat household. If clumps are stuck to the litter pan, remove using the provided scraper. For multiple cat homes, maintenance may need to occur more frequently.

How do I clean the litter pan and waste unit?

Cleaning Smart Scoop's components couldn't be easier! Simply remove the waste unit and motor unit from the litter pan and clean pan with warm, soapy water. The litter rake can be removed from the waste unit so that it can be cleaned as well. **Do not submerge motor unit in water**, as this can damage Smart Scoop.

TROUBLESHOOTING

Issue	Resolution
Mode light is blinking red or solid red	Unit has encountered excessive resistance. Power off unit. Unlock clutch. Remove obstruction. Move unit back to ready position. Lock clutch. Power unit back on.
Unit will not operate	<p>Make sure motor unit cord is connected to power cord, and power cord is plugged in to a functioning outlet.</p> <p>Clutch may not be engaged. Move motor / waste unit to the “ready” position and engage clutch.</p> <p>Be sure that the unit is powered on. The MODE light will be solid green to indicate it is in automatic mode.</p>
Cleaning cycle doesn't start	<p>Dirty sensor. Clean sensor lens with a soft, dry cloth.</p>
Waste unit and/or motor unit binds and gets stuck	<p>Make sure the motor unit and waste unit are fully engaged. You should hear a “CLICK” when assembling if they are assembled properly</p> <p>Close the rake safety door.</p>
Unit struggles through a cleaning cycle	<p>Litter level may be too high.</p> <p>Litter may be built up near the edge of the pan. Even out litter in the pan.</p>
Waste is stuck behind rake	Stop unit, lift rake and clear obstruction.
Waste lid isn't closing	<p>The waste unit may be full. Remove waste.</p>
I can't remove waste unit. It seems to be stuck.	<p>Litter may have fallen into latch area preventing latch from operating properly. Vacuum litter from latch area.</p>

More help can be found by visiting www.petzonebrand.com or by calling **1-800--565-2695**.

CUSTOMER CARE

If you have any questions that cannot be answered by this manual, please contact our Customer Care Department.

Web: www.petzonebrand.com
Email: customerservice@ourpets.com
Phone: 1-800-565-2695

Please allow at least one business day to receive an answer via email.

Smart Scoop is committed to your satisfaction, and we want you to be happy with your purchase. We will do our best to resolve any assembly, operation or performance issues with Smart Scoop, but we cannot accept returns or refund purchases made at retail stores. All returns and refunds must go through the store, website or catalog from which you purchased Smart Scoop and are subject to their return and refund policy.

OTHER GREAT SMARTSCOOP® PRODUCTS FOR A FRESHER LITTER BOX

NO-TOUCH WASTE BAGS

- Simply place No-Touch Waste Bags over the waste tray – when it's full, just toss!
- Seal away waste, clumps and odors



ACTIVATED CARBON FILTERS

- Continuously absorbs odors and is easy to discard along with a filled waste bag
- Safe, natural and non-toxic
- Individually wrapped to maintain maximum effectiveness

These products may be purchased at your local retailer or they can be found at www.petzonebrand.com.